

CYLINDRA FIRE TABLE

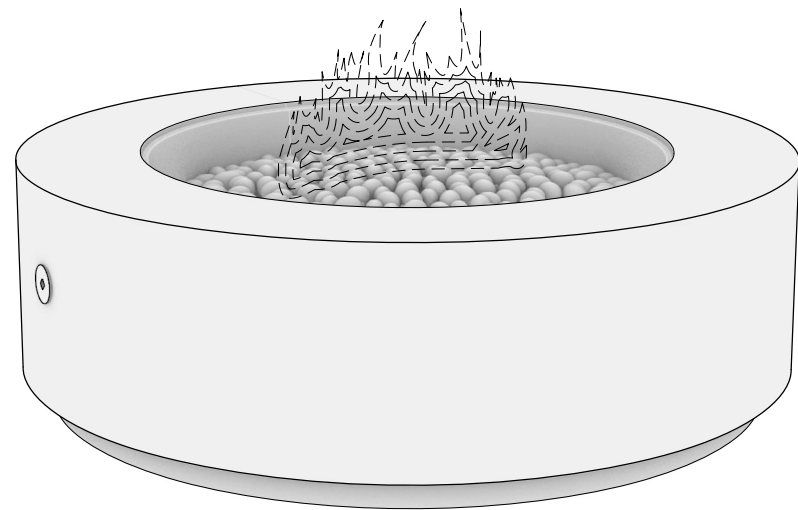

CY.1.1 PERSPECTIVE VIEW
SCALE: NA

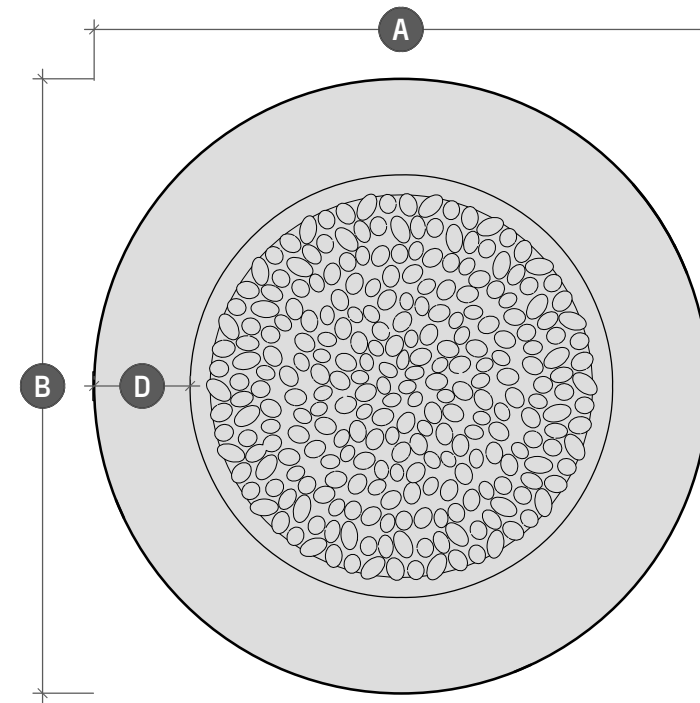

CY.1.2 PLAN VIEW
SCALE: 1" = 1' - 3"

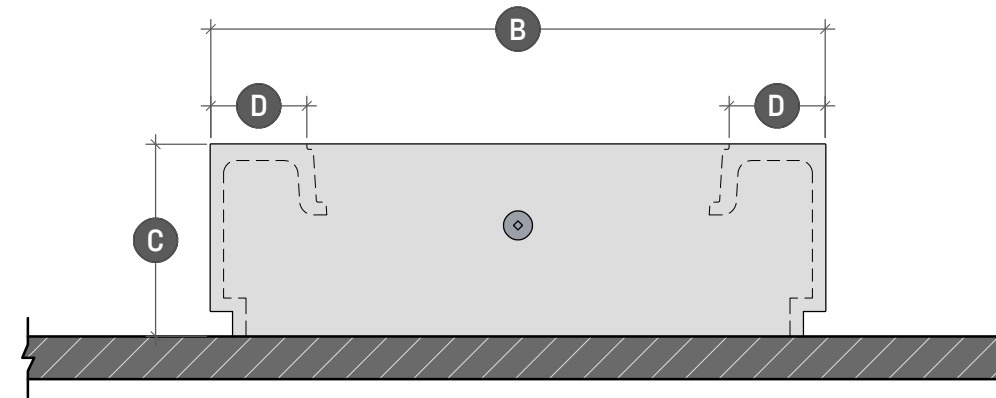

CY.1.3 SIDE ELEVATION
SCALE: 1" = 1' - 3"

	CYLINDRA 36	CYLINDRA 42	CYLINDRA 48	CYLINDRA 52
Length	A - 36"	A - 42"	A - 48"	A - 52"
Width	B - 36"	B - 42"	B - 48"	B - 52"
Height	C - 15"	C - 15"	C - 15"	C - 15"
Surface	D - 5 1/2"	D - 6 1/2"	D - 7 1/2"	D - 9 1/2"

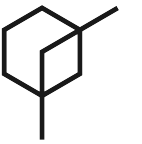

LUMACAST

3261 National Ave
San Diego, CA 92113
t: +1 888 710 1026
www.lumacast.com

PROJECT INFORMATION

PROJECT:
LUMACAST FIRE TABLE
CYLINDRA

DESIGNER:
LUMACAST

DRAWING INFORMATION

DRAWING PACKAGE:
2D SHOP DRAWINGS
SHEET CONTENTS:
COVER SHEET

MORE INFORMATION



SCAN TO LEARN MORE

AUTHOR AUTHOR
EGI 09/23

CY.1

SHEET NO

MINIMUM CLEARANCES TO COMBUSTIBLES

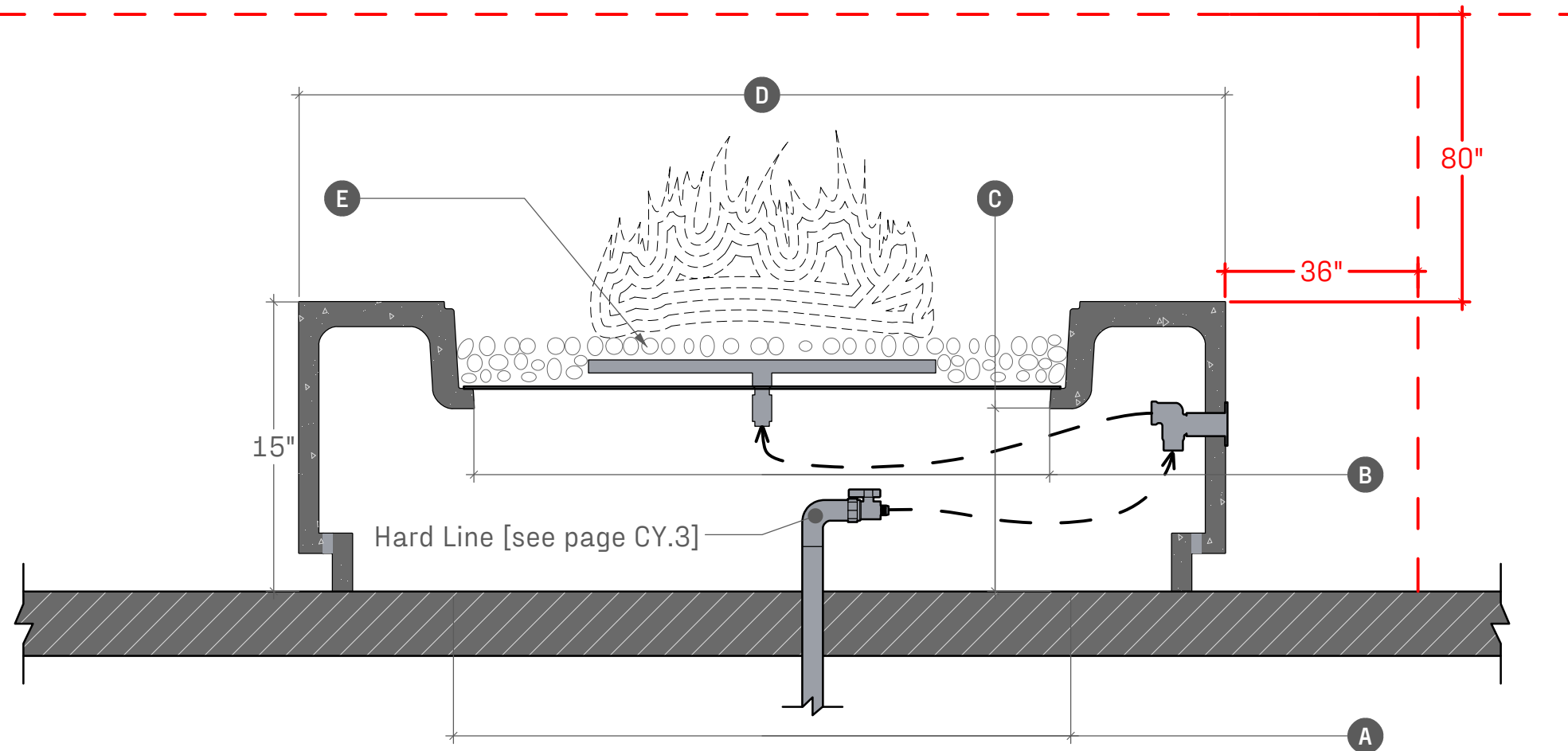

CY.2.1 SECTION DETAIL
SCALE: 1" = 0' - 8"

	CYLINDRA 36	CYLINDRA 42*	CYLINDRA 48*	CYLINDRA 52
Opening at Base	A - 30"	A - 36"	A - 42"	A - 46"
Burner Pan Access	B - 21"	B - 25"	B - 30"	B - 32"
Burner Pan Height	C - 10"	C - 10"	C - 10"	C - 10"
Length	D - 36"	D - 42"	D - 48"	D - 52"
Burner Options	E - - -	E - - -	E - - -	E - - -
Stainless Steel Burner	88,000 BTU	95,000 BTU	95,000 BTU	150,000 BTU
Warming Trands Burner	84,000 BTU	120,000 BTU*	180,000 BTU*	280,000 BTU
Crated Dimensions	39"x39"x23"	45"x45"x23"	51"x51"x23"	56"x56"x23"
Shipping Weight	- 450 LBs	- 580 LBs	- 725 LBs	- 725 LBs
Shell Weight	- 230 LBS	- 280 LBs	- 335 LBs	- 375 LBs

! WARNINGS !

FOR OUTDOOR USE ONLY

POTENTIAL CARBON MONOXIDE HAZARD

Do not store or use flammable liquids in the vicinity of this product

To be installed by licensed plumber or contractor

TYPICAL CLEARANCES

36" of clearance from the side elevations of the fire table

80" of clearance from the top surface of the fire table

NATURAL GAS SUPPLY

Ensure that the service supplying the fire feature is fitted with a positioned shut off valve that is easily accessible

SUPPLY PRESSURE

Minimum - 3.5" WC

Normal - 7.0" WC

Maximum - 14.0" WC (1/2psi)

- - -

Check with local inspector if any further specifications are required for permitted installations



LUMACAST

3261 National Ave
San Diego, CA 92113
t: +1 888 710 1026
www.lumacast.com

PROJECT INFORMATION

PROJECT:
LUMACAST FIRE TABLE
CYLINDRA

DESIGNER:
LUMACAST

DRAWING INFORMATION

DRAWING PACKAGE:
2D SHOP DRAWINGS
SHEET CONTENTS:
SPECIFICATIONS

MORE INFORMATION



SCAN TO LEARN MORE

AUTHOR AUTHOR
EGI 09/23

CY.2

SHEET NO

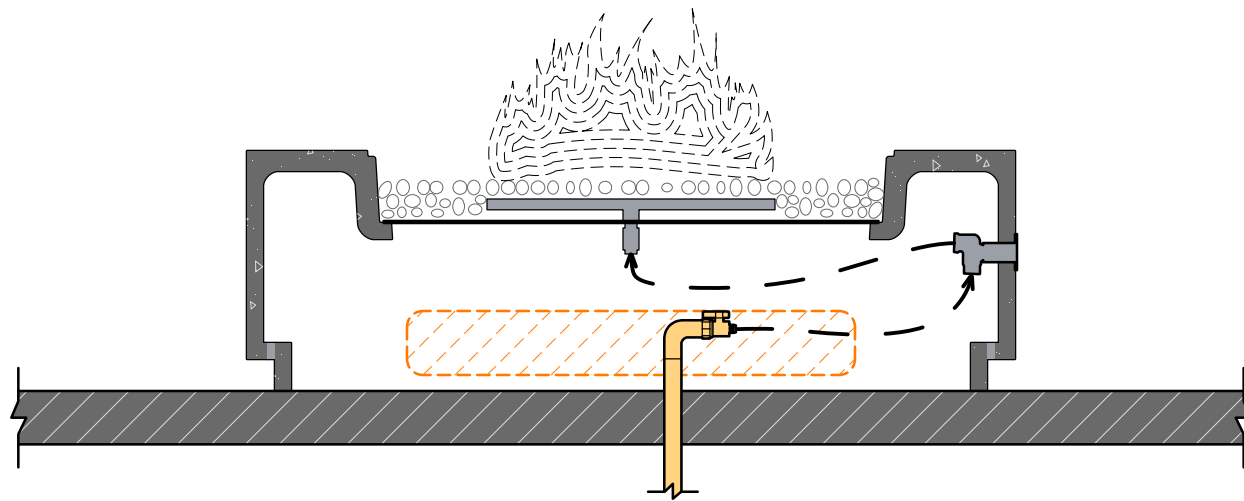

CY.3.1 SIDE SECTION
SCALE: 1" = 1' - 0"

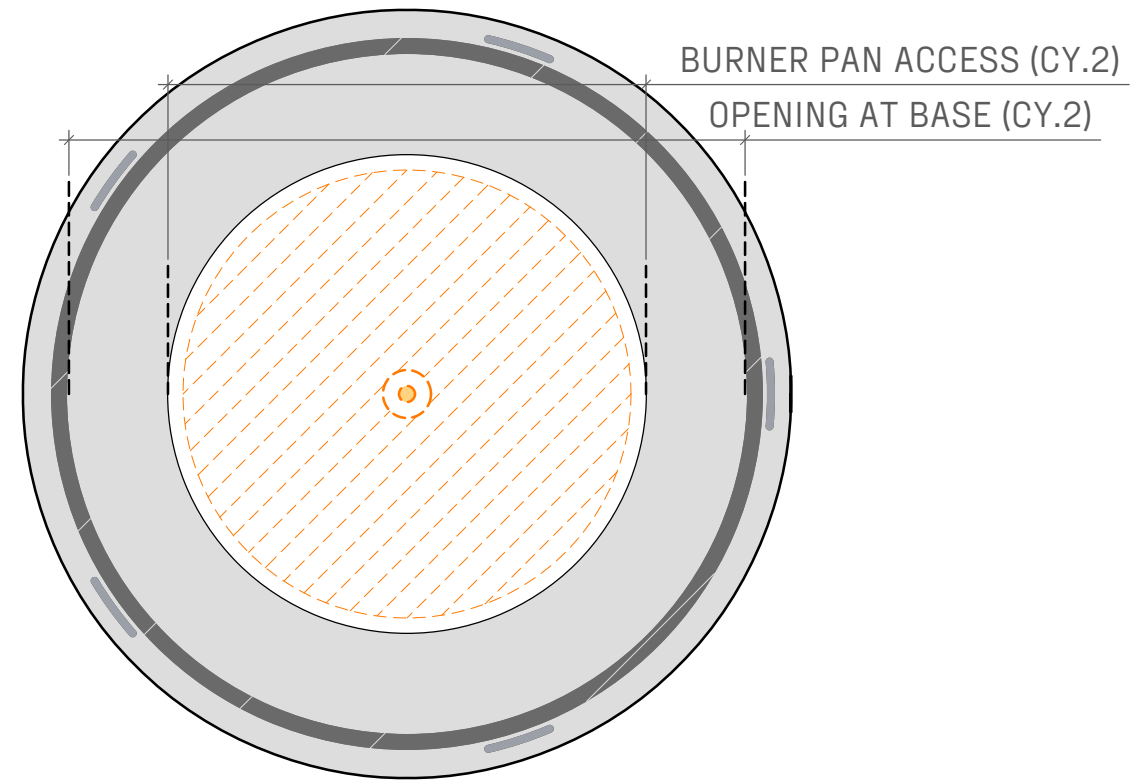

CY.3.2 PLAN VIEW
SCALE: 1" = 1' - 0"

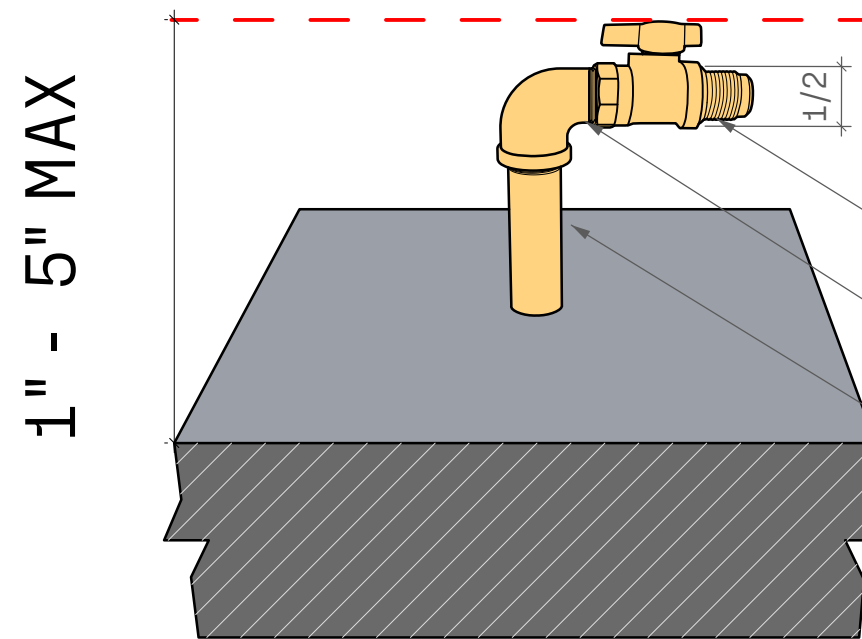

CY.3.3 PERSPECTIVE
SCALE: n/a

- BRASS FNPT X FLARE GAS BALL VALVE: 1/2" STREET ELBOW
- GALVANIZED NIPPLE 3/4" - 1" DEPENDING ON BTU SEE PLUMBER

PLUMBING HARD LINE

For successful installation, hardline stub up should be capped off between 1" and 5" off finished floor.

Lumacast White Glove Delivery and Installation can only be done on IPS Piping



LUMACAST

3261 National Ave
San Diego, CA 92113
t: +1 888 710 1026
www.lumacast.com

PROJECT INFORMATION

PROJECT:
LUMACAST FIRE TABLE
CYLINDRA

DESIGNER:
LUMACAST

DRAWING INFORMATION

DRAWING PACKAGE:
2D SHOP DRAWINGS
SHEET CONTENTS:
HARDLINE DIAGRAM

MORE INFORMATION



SCAN TO LEARN MORE

AUTHOR	AUTHOR
EGI	09/23